

Roof transition

TGKOMR



Description

Roof transition adapted for combi-hood HKOMR. The transition is produced with 50 mm fire or condensation insulation. At connection to circular duct two lower connections TGKOMR-NA are used. The roof transition is manufactured as standard in galvanised steel plate, but is available in stainless steel sheet 1.4301, stainless acid-resistant steel sheet 1.4404, or painted. Two angle brackets are supplied for adaptation to the relevant roof incline. Sizes and dimensions according to drawing and table, but is available in extended version which is specified separately. The duct connections are supplied with RJFP joints for guiding.

Ordering example

	TGKOMR	3	1	2	1
Product					
Size					
Type of insulation					
Fire protection 50 mm			1		
Condensation 50 mm			2		
Internal cladding of insulation					
Zink plated steel			1		
Zink plated perf. steel			2		
Stainl. acid-res. steel 1.4404			5		
Stainl. acid-res. steel perf. 1.4404			6		
No internal cladding (Only applicable at condensation insulation)			7		
Stainless steel 1.4301			8		
External material					
Zink plated steel			1		
Stainl. acid-res. steel 1.4404			3		
Stainless steel 1.4301			4		

Dimensions

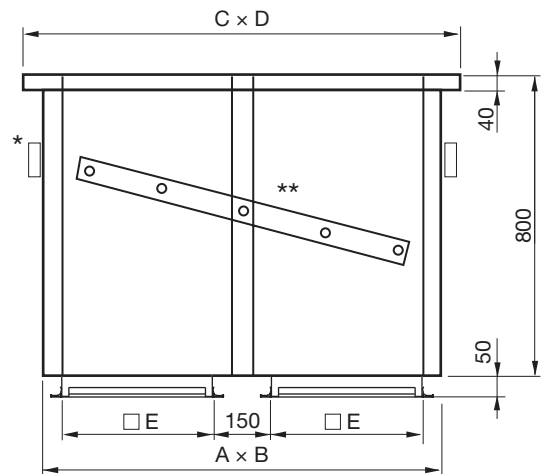

Size	A mm	B mm	C mm	D mm	E mm	m kg
2	650	300	740	390	200	32,5
3	850	400	940	490	300	43,5
4	1050	500	1140	590	400	54,3
5	1250	600	1340	690	500	72,4
6	1450	700	1540	790	600	84,5
8	1850	900	1940	990	800	113
10	2250	1100	2340	1190	1000	138
12	2650	1300	2740	1390	1200	190
14	3050	1500	3140	1590	1400	251

Hole punching dimensions = $(A + 20) \times (B + 20)$
 * and ** are alternative positions for angle brackets

TGKOMR-NA

- Lower connection

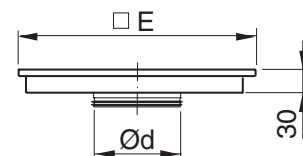

Accessories

	TGKOMR-NA	3	125	1
Lower connection				
Product				
Size				
Connection measure				
Material				
Zink plated steel			1	
Stainl. acid-res. steel 1.4404			3	
Stainless steel 1.4301			4	